

# DAPCO®

## Power Cam™ and Power Pump™ System

**NEW!**



- Ideal for secondary operations such as punching, piercing, forming or flanging
- Power Cam™ may be installed and operated in any orientation
- 15 kN and 40 kN force models



## **Guided Hydraulic Die Cam with Nitrogen Return**

# DADCO®

DADCO produces top quality products at competitive prices and provides a superior level of customer service. Founded in 1958, DADCO is the highest volume producer of gas springs for press tools. DADCO's products are widely approved and used in global operations for many industries including metal stamping, automotive and plastic injection molding.

### Power Cam™ and Power Pump™ System

Designed for use in dies requiring secondary operations, DADCO's new Power Cam™ and Power Pump™ System features high quality, guided components to ensure exceptionally long service life. Each system requires at least one Power Cam™, one Power Pump™ and a communication method between the two, such as hydraulic hose.

When a Power Pump™ and Power Cam™ of the same series and stroke are paired, the Power Pump™ will transfer its travel, speed and pressure to the Power Cam™ on a 1:1 basis because the piston area of the Pump's Hydraulic Cylinder and the Power Cam™ are the same.



DADCO offers two Power Cam™ and Power Pump™ Systems with different force ratings to accommodate a variety of operations.

System	Force
Power Cam™ and Power Pump™ – 15	15.40 kN 3463 lb.
Power Cam™ and Power Pump™ – 40	40.31 kN 9062 lb.

### Power Pump™

The Power Pump™ consists of a Hydraulic Cylinder and Nitrogen-Over-Oil Accumulator mounted to a Base Manifold. The pump is typically installed upright but may be inverted and placed in any location where the cylinder's plunger can be driven by the press (and the Accumulator will have sufficient clearance).

The system pressure is limited by the charging pressure of the Accumulator. See the charts on pages 6 and 8 for various Accumulator nitrogen charging pressures and resultant Power Cam™ force ratings.

The Accumulator absorbs any pressure spikes in the system. If pressure ever exceeds the rating of the system materials, a safety disc will exhaust the high pressure inert gas.

### Power Cam™

The Power Cam™ is a compact actuator designed to perform in-die secondary operations, such as punching, piercing, forming or flanging. Both the Power Cam™-15 and Power Cam™-40 incorporate small DADCO nitrogen gas springs for reliable return or stripping force. Constructed of long wearing, close-fitting components, the Power Cam™ provides durable operation. The base of the Power Cam™ has two mounting holes and a keyway with supplied key to withstand thrust. Additionally, two dowel holes are provided for precise positioning.

### Hose and Fittings

DADCO offers a full range of fluid hose and fittings to connect the Power Pump™ and Power Cam™. Compatible hose, hose protectors and fittings are in stock and ready to ship, providing everything needed from one source. For added convenience, DADCO also offers accessories recommended for safe and easy system filling and draining. For more information refer to page 13.



### Customer Satisfaction

DADCO's motto is "Whatever It Takes To Satisfy Our Customers." DADCO will assist in any way possible to ensure that customers are completely satisfied. DADCO's salespeople and distributors are solution-oriented, product-knowledgeable, and eager to assist customers. DADCO's engineers are available to help customers with specific applications.

### Warranty

DADCO warrants its Power Cam™ and Power Pump™ systems to be free from defects in workmanship or materials for a period of one year from date of manufacture.

### CAD Templates

DADCO's entire product line is available on-line in solid models and 2D CAD formats. For more information, visit our website, [www.dadco.net](http://www.dadco.net), or contact DADCO.

# System Components and Features

## Power Cam™ and Power Pump™ System

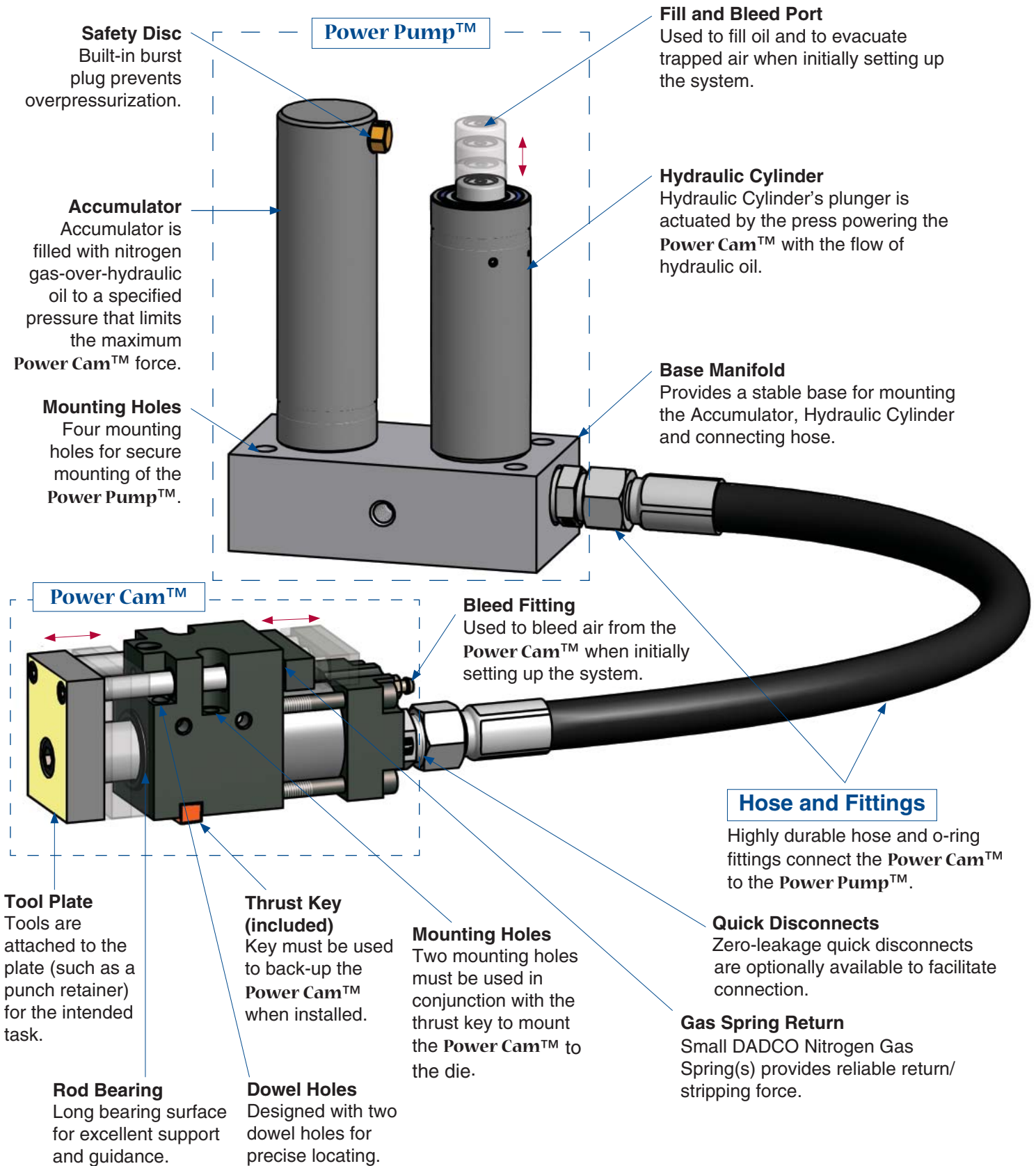

## Operation Overview

1

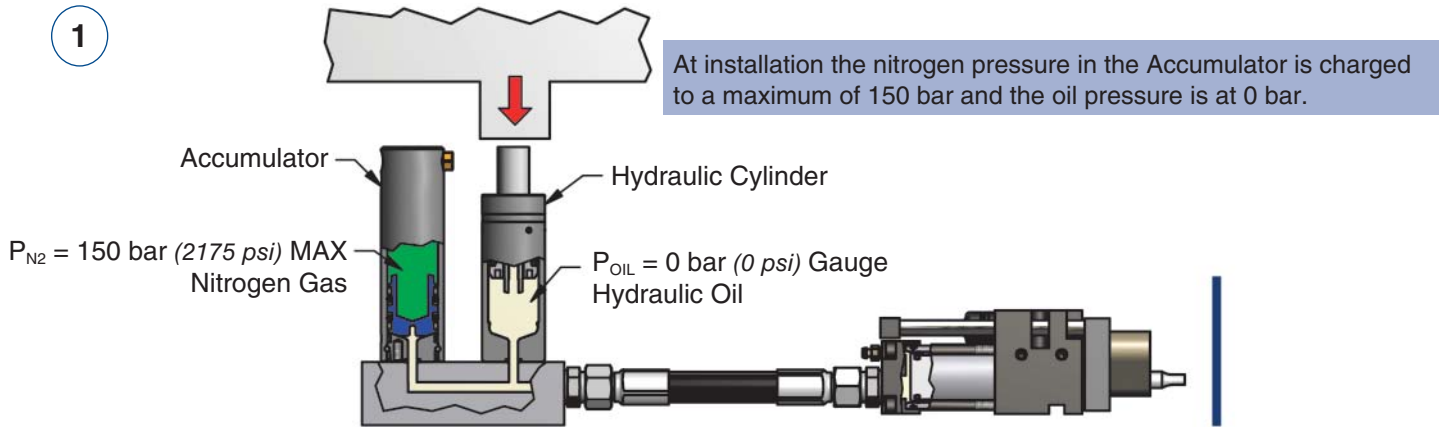

2

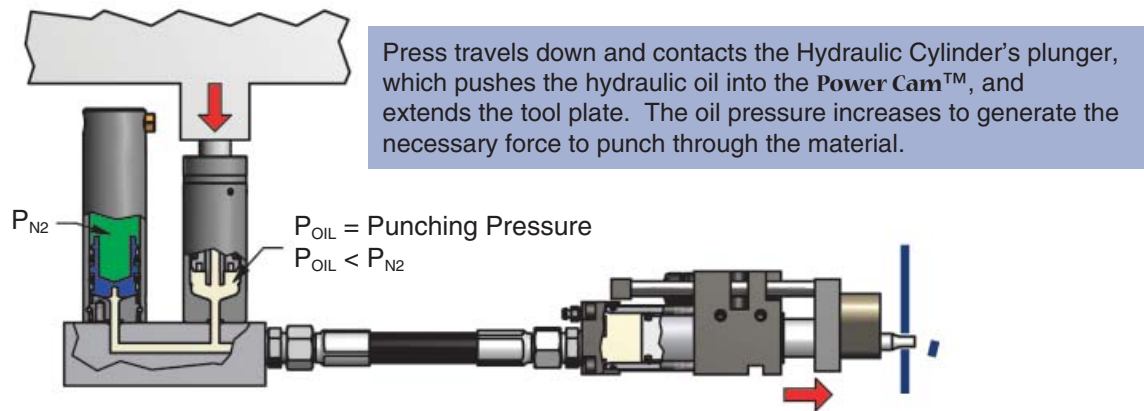

3

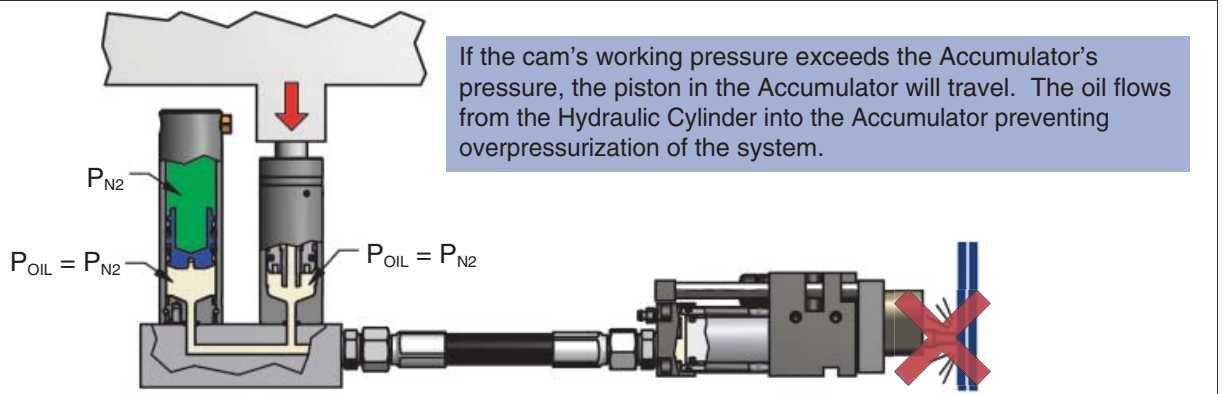
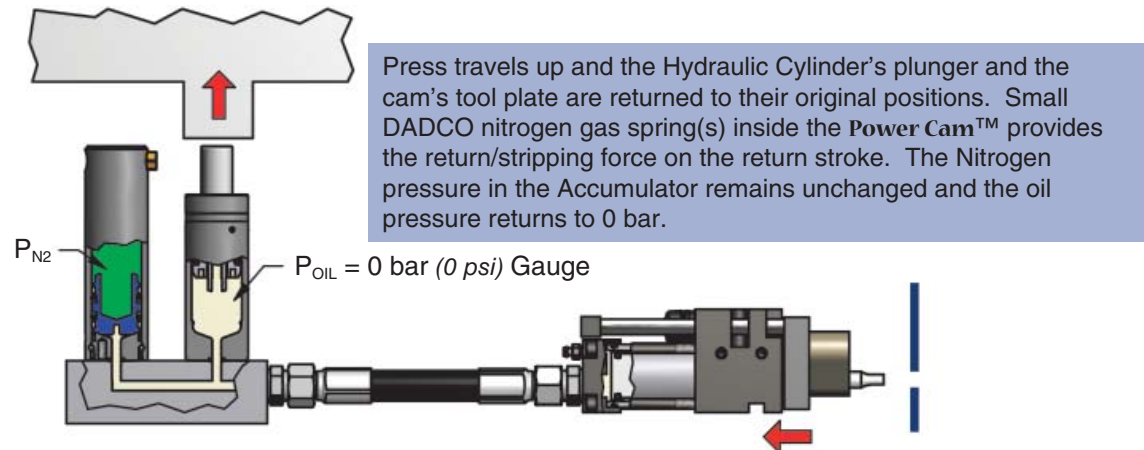

## Application Examples

DADCO's **Power Cam™** and **Power Pump™** System is typically used for in-die secondary operations (punching, piercing, forming, flanging, etc.) and may replace existing tooling to create a simplified design thus saving time and money. The **Power Cam™** can be installed in any orientation while the **Power Pump™** must be installed either vertically or inverted. Refer to the application examples below. Contact DADCO for more information.

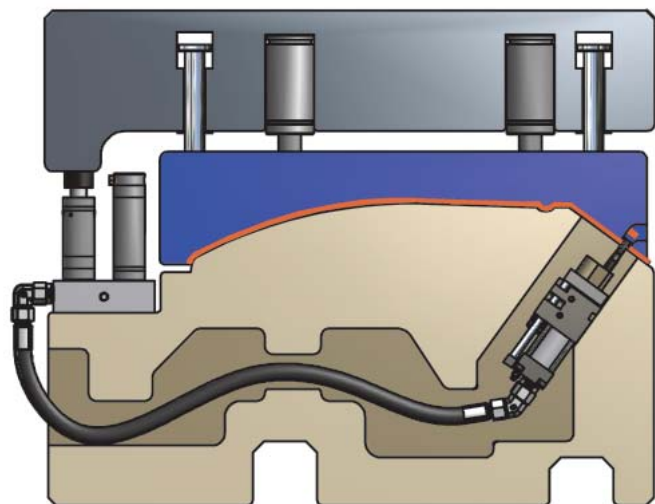

The **Power Cam™** is installed in the die at an angle to punch a hole in an angled piece of sheet metal. The **Power Pump™** is mounted to the side of the lower die. As the press cycles, the part is shaped; the plunger of the Hydraulic Cylinder is depressed, powering the cam to punch through the material.

Small DADCO nitrogen gas spring(s) affixed to the **Power Cam™** provides the stripping force on the return stroke.

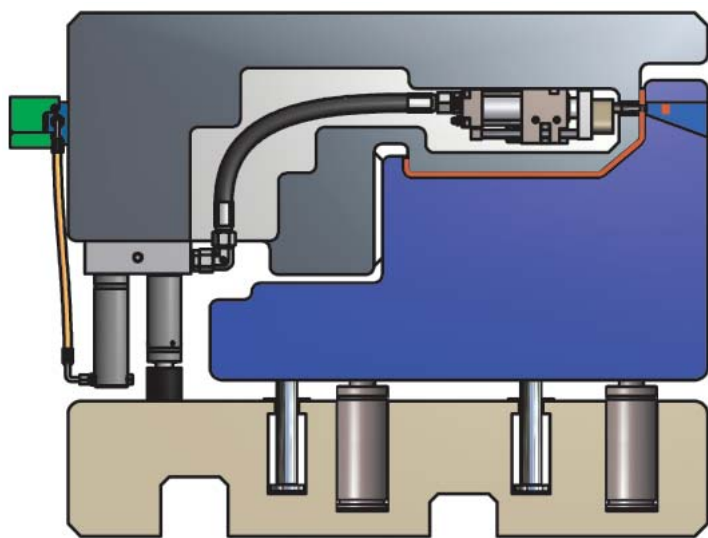

The **Power Cam™** is installed in a horizontal application where the part is formed and pierced in the same operation allowing for increased productivity. The **Power Cam™** and **Power Pump™** System may be monitored from outside the die using a control panel. Refer to Catalog #C09118 for a comprehensive list of DADCO nitrogen gas spring linked system components.

It is important to maintain adequate clearance for the Accumulator and prevent side load on the Hydraulic Cylinder. Side loading causes increased wear on the cam components. Refer to pages 11-12 for additional installation recommendations.

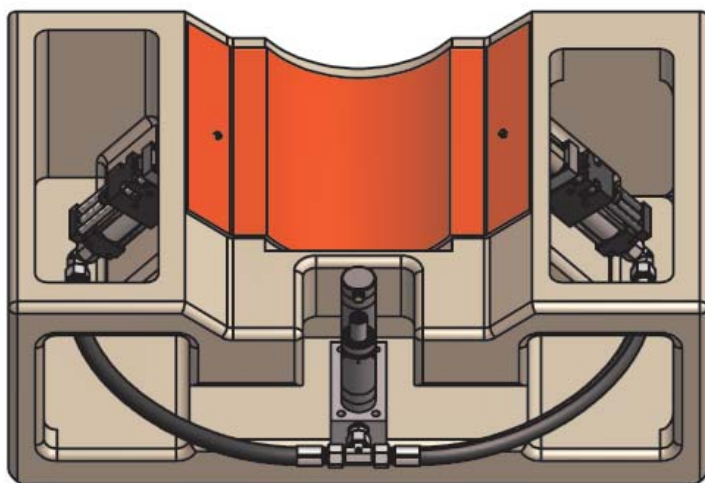

Multiple cams can be linked to one **Power Pump™**, however only when the cams do not require synchronization. When linked, the cams may not extend at the same speed and will only be synchronized at full stroke. Best practice suggests connecting the cams to the **Power Pump™** with equal hose length. Contact DADCO for more information.

*When synchronized movement is required, DADCO recommends connecting one **Power Cam™** per **Power Pump™**.*

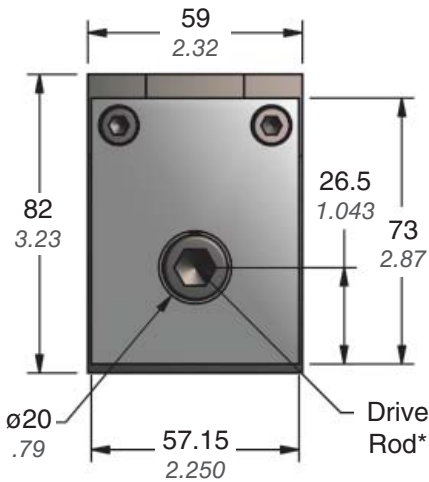
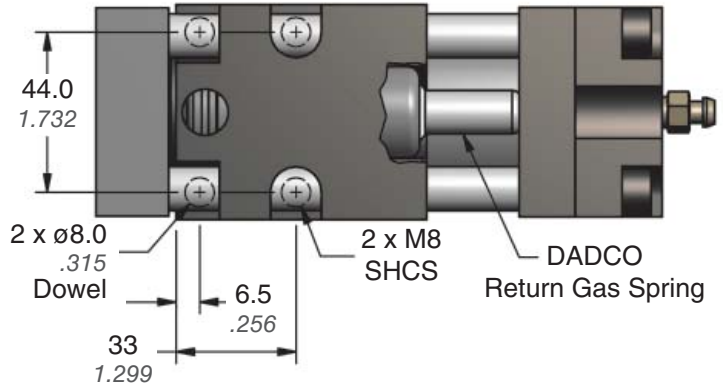

\*For best performance mount tool in the center of the drive rod.

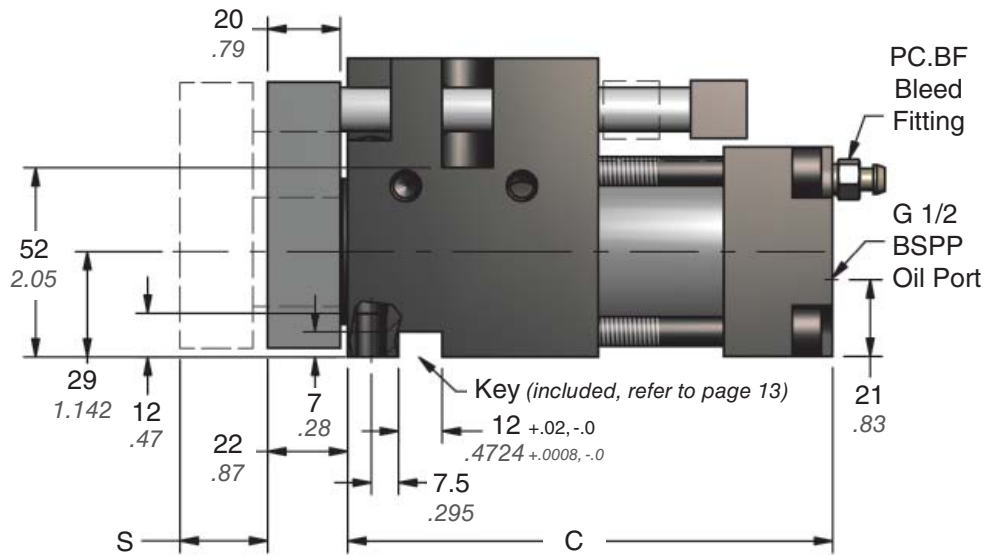

### Maximum Force

#### Imperial

Pressure (psi)	Force (lb.)	Pressure (bar)	Force (kN)
2175	3463	150	15.40
1750	2635	125	12.26
1500	2148	100	9.12
1000	1174	75	5.98
750	687	50	2.84

Based on Accumulator's nitrogen charging pressure.

#### Metric

Part No.	S mm inch	C	Return Gas Spring
PC.C.015.024	24.0 0.94	133.5 5.26	C.180.025.BK
PC.C.015.049	49.0 1.93	158.5 6.24	C.180.050.BK

Return/Stripping Force	1.55 kN 348 lb.
------------------------	--------------------

### Ordering Example:

**PC.C.015. 024**

**Part Number:** \_\_\_\_\_  
Includes Series and Model

**Stroke Length (mm):** \_\_\_\_\_  
24 or 49

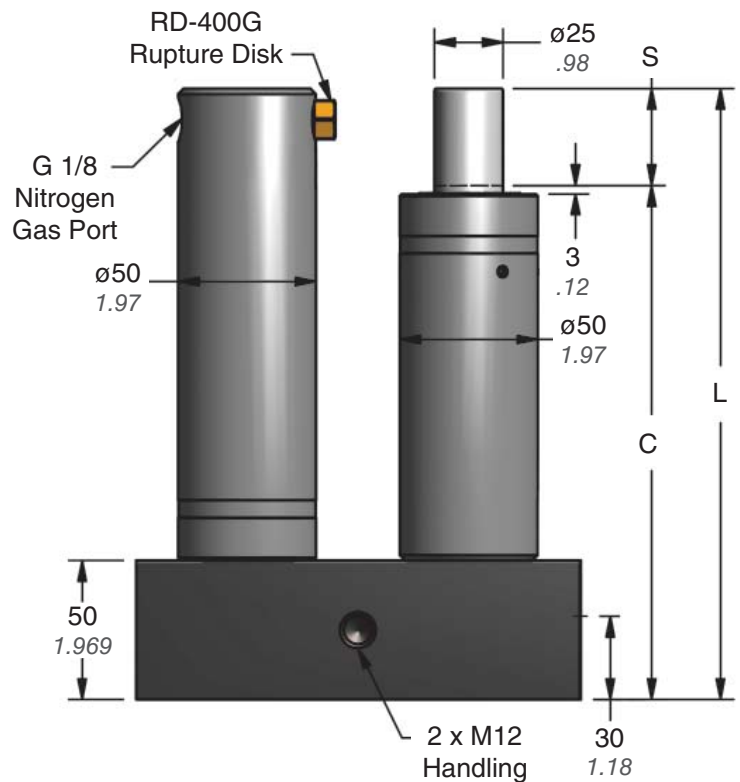
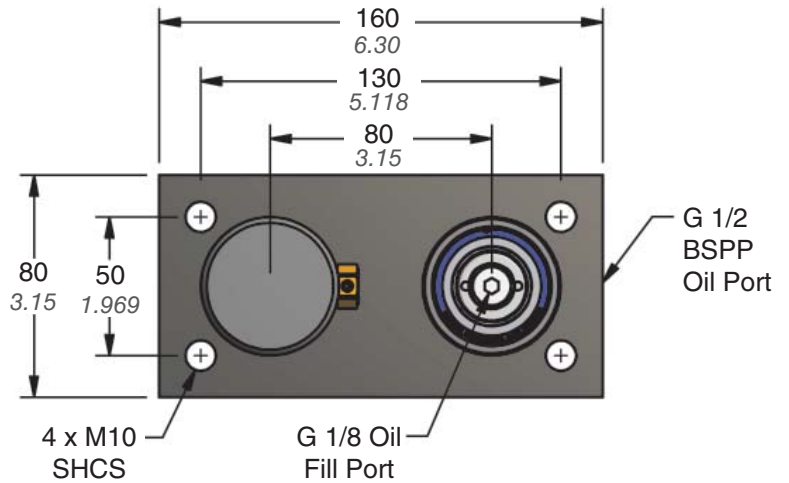

Part No.	S mm inch	C	L
PP.B.015.035	35.0 1.38	185.0 7.28	220.0 8.661
PP.B.015.060	60.0 2.36	210.0 8.27	270.0 10.630
PP.B.015.110	110.0 4.33	260.0 10.24	370.0 14.567

### Ordering Example:

**PP.B.015. 035**

**Part Number:**  
Includes Series and Model

**Stroke Length (mm):**  
035, 060 or 110

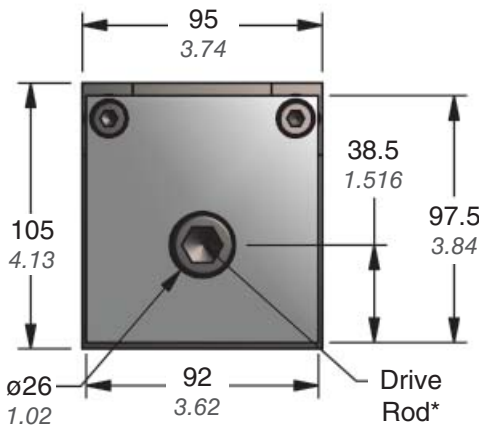
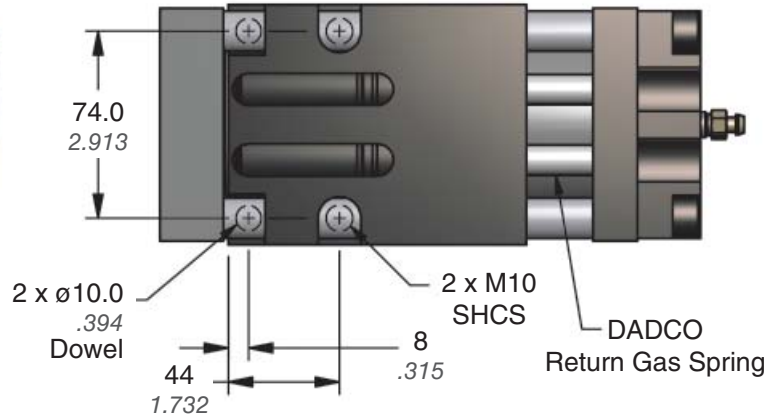

\*For best performance mount tool in the center of the drive rod.

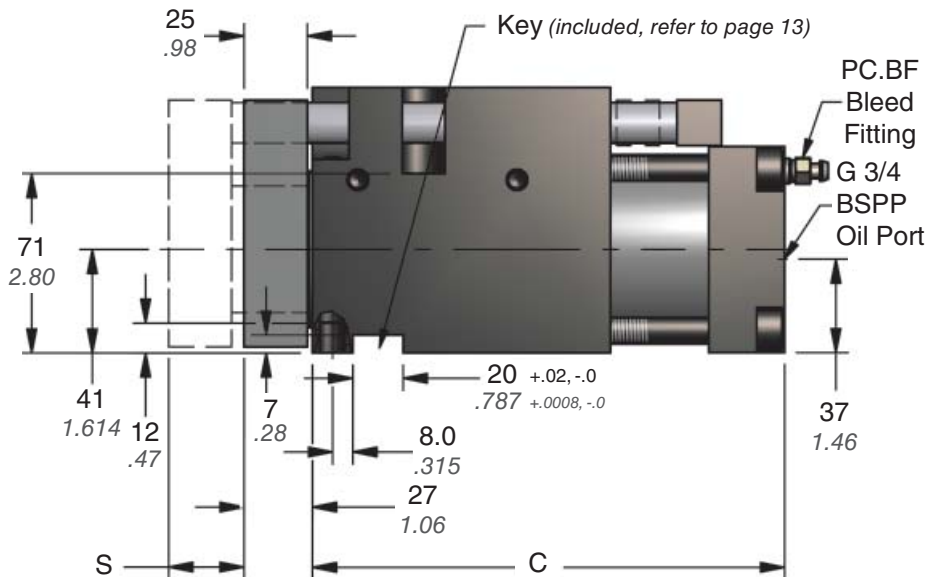

### Maximum Force

#### Imperial

Pressure (psi)	Force (lb.)	Pressure (bar)	Force (kN)
2175	9062	150	40.31
1750	7009	125	32.52
1500	5801	100	24.73
1000	3385	75	16.94
750	2177	50	9.15

#### Metric

Part No.	S mm inch	C	(2) Return Gas Spring
PC.C.040.024	24.0 0.94	187 7.36	C.180.025.BK
PC.C.040.049	49.0 1.93	212 8.35	C.180.050.BK
PC.C.040.099	99.0 3.90	262 10.31	C.180.100.BK
PC.C.040.124	124.0 4.88	287 11.30	C.180.125.BK

Based on Accumulator's nitrogen charging pressure.

Return/Stripping Force	3.55 kN 800 lb.
------------------------	--------------------

### Ordering Example:

**PC.C.040. 024**

Part Number:  
Includes Series and Model

Stroke Length (mm):  
24, 49, 99 or 124

# Power Pump™ – 40 kN

# Power Cam™ and Power Pump™ System

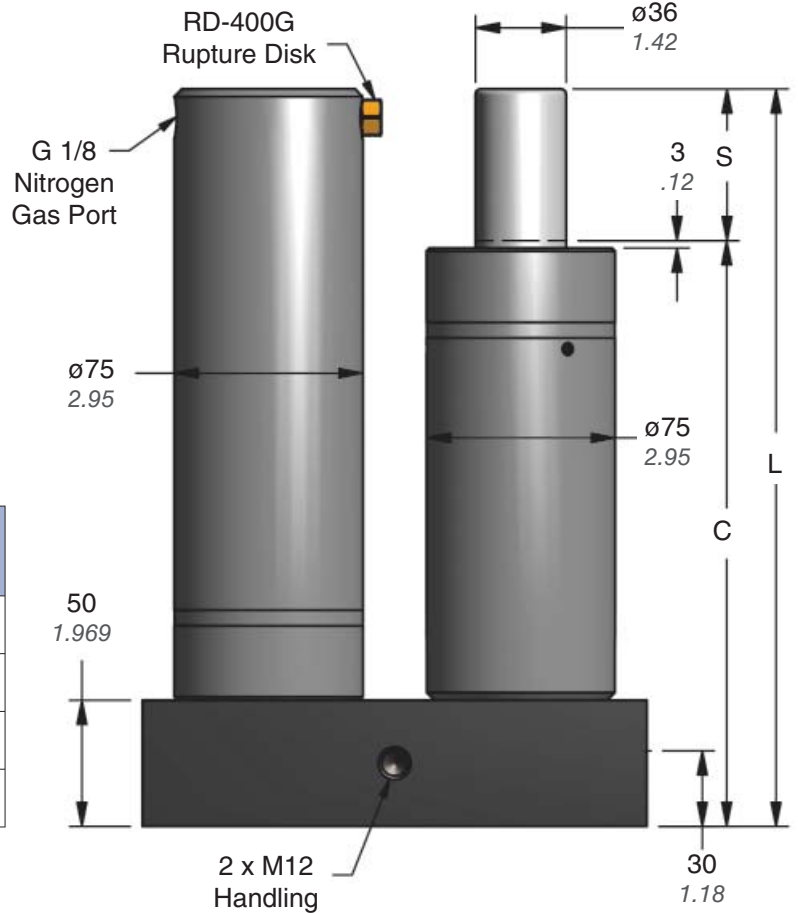
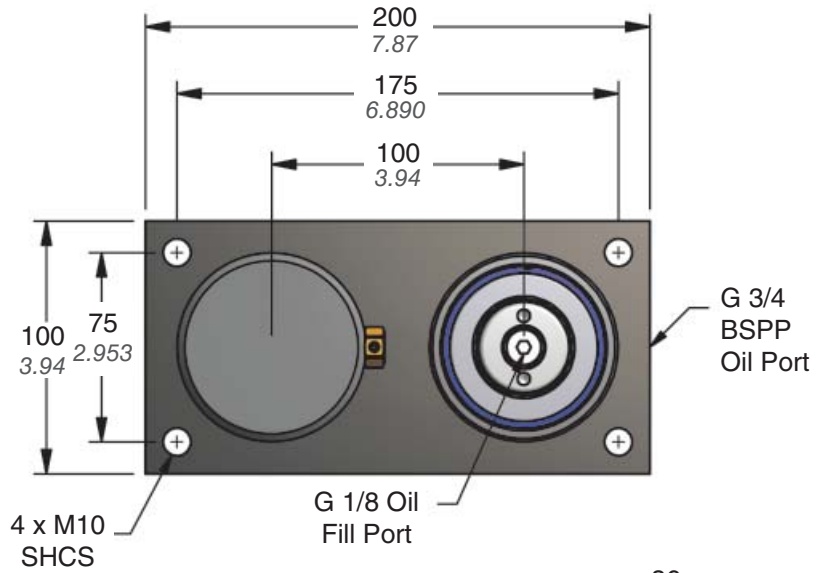

Part No.	S mm inch	C	L
PP.B.040.035	35.0 1.38	207.0 8.15	242.0 9.528
PP.B.040.060	60.0 2.36	232.0 9.13	292.0 11.496
PP.B.040.110	110.0 4.33	282.0 11.10	392.0 15.433
PP.B.040.160	160.0 6.30	332.0 13.07	492.0 19.370

## Ordering Example:

**PP.B.040. 035**

**Part Number:**  
Includes Series and Model

**Stroke Length (mm):**  
035, 060, 110 or 160

### Hydraulic Hose and Adapter

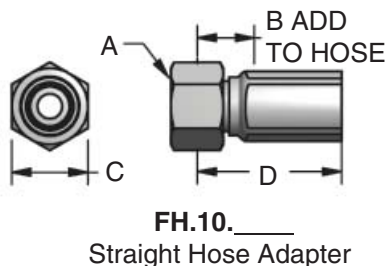
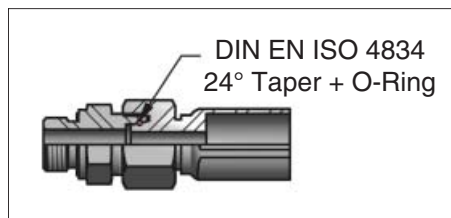

Part No.	FH.10.C08.D16 (for 90.800 Hose)	FH.10.C12.D20 (for 90.1200 Hose)
A	M24 x 1.5	M30 x 2.0
B	24 .94	25 .98
C	30 1.18	36 1.42
D	56 2.20	64 2.52

	For use with PP.B.015 and PC.C.015	For use with PP.B.040 and PC.C.040
	90.800 (Y-800) Hose	90.1200 (Y-1200) Hose
OD	24 .93	31 1.21
ID	12.5 .50	19 .75
Working Pressure	280 bar 4000 psi	280 bar 4000 psi
Burst Pressure	1100 bar 16000 psi	1100 bar 16000 psi
Bend Radius	90 3.50	120 4.75
Crimp Die	83C-D08	83C-D12

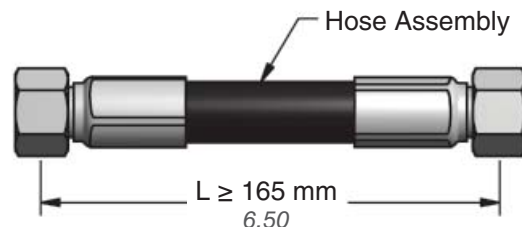

#### Hose Assembly Ordering Codes:

90.800.D16.D16.\_\_\_\_.L  
L (mm)

90.1200.D20.D20.\_\_\_\_.L  
L (mm)

Do not exceed 2000 mm hose length.

### Port Adapters

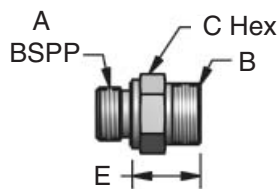

**FP.10.\_\_\_\_**  
Straight

Part No.	FP.10.G08.D16	FP.10.G12.D20
A	G 1/2	G 3/4
B	M24 x 1.5	M30 x 2.0
C	27 1.06	32 1.26
E	27 1.06	31 1.22

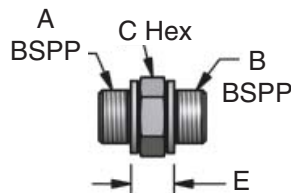

**FP.10.\_\_\_\_**  
Straight

Part No.	FP.10.G08.G08	FP.10.G12.G12
A	G 1/2	G 3/4
B	G 1/2	G 3/4
C	27 1.06	32 1.26
E	19.3 .76	15 .59

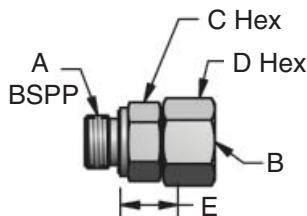

**FP.13.\_\_\_\_**  
Swivel Nut Straight

Part No.	FP.13.G08.D16	FP.13.G12.D20
A	G 1/2	G 3/4
B	M24 x 1.5	M30 x 2.0
C	27 1.06	32 1.26
D	30 1.18	36 1.42
E	28.5 1.12	34 1.34

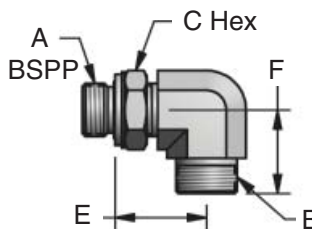

**FP.20.\_\_\_\_**  
90° Elbow

Part No.	FP.20.G08.D16	FP.20.G12.D20
A	G 1/2	G 3/4
B	M24 x 1.5	M30 x 2.0
C	27 1.06	36 1.42
E	36 1.42	39 1.54
F	33 1.30	38 1.50

# Hose and Fittings

## Fittings

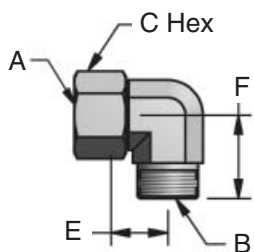

**FS.20.**  
Swivel Nut 90° Elbow

Part No.	FS.20.ZZZ.D16	FS.20.ZZZ.D20
A	G 1/2	G 3/4
B	M24 x 1.5	M30 x 2.0
C	30 1.18	36 1.42
E	28 1.10	35.5 1.40
F	33 1.30	37 1.46

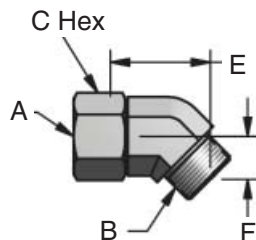

**FS.30.**  
Swivel Nut 45° Elbow

Part No.	FS.30.ZZZ.D16	FS.30.ZZZ.D20
A	G 1/2	G 3/4
B	M24 x 1.5	M30 x 2.0
C	30 1.18	36 1.42
E	45.5 1.79	54.5 2.15
F	17 .67	19 .75

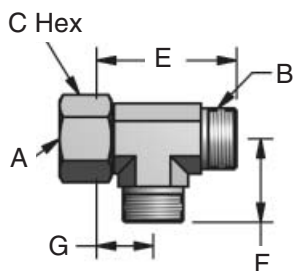

**FS.50.**  
Run Tee

Part No.	FS.50.ZZZ.D16	FS.50.ZZZ.D20
A	G 1/2	G 3/4
B	M24 x 1.5	M30 x 2.0
C	30 1.18	36 1.42
E	61 2.40	72.5 2.85
F	33 1.30	37 1.46
G	28 1.10	35.5 1.40

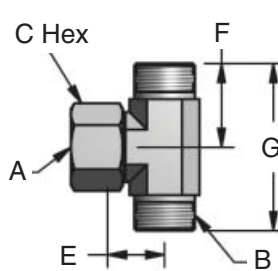

**FS.40.**  
Branch Tee

Part No.	FS.40.ZZZ.D16	FS.40.ZZZ.D20
A	G 1/2	G 3/4
B	M24 x 1.5	M30 x 2.0
C	30 1.18	36 1.42
E	28 1.10	35.5 1.40
F	33 1.30	37 1.46
G	66 2.60	74 2.91

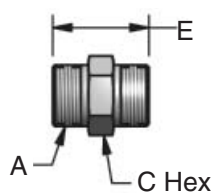

**FN.10.**  
Union

Part No.	FN.10.ZZZ.D16	FN.10.ZZZ.D20
A	M24 x 1.5	M30 x 2.0
C	27 1.06	32 1.26
E	38 1.50	44 1.73

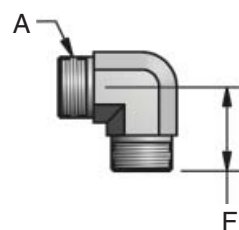

**FN.20.**  
Union Elbow

Part No.	FN.20.ZZZ.D16	FN.20.ZZZ.D20
A	M24 x 1.5	M30 x 2.0
F	33 1.30	37 1.46

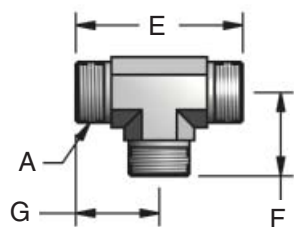

**FN.40.**  
Union Tee

Part No.	FN.40.ZZZ.D16	FN.40.ZZZ.D20
A	M24 x 1.5	M30 x 2.0
E	66 2.60	74 2.91
F	33 1.30	37 1.46
G	33 1.30	37 1.46

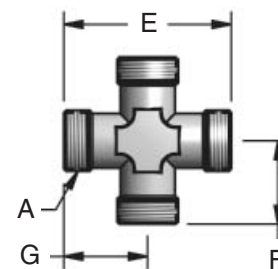

**FN.60.**  
Union Cross

Part No.	FN.60.ZZZ.D16	FN.60.ZZZ.D20
A	M24 x 1.5	M30 x 2.0
E	66 2.60	74 2.91
F	33 1.30	37 1.46
G	33 1.30	37 1.46

**Quick Disconnects (Zero Leakage)**

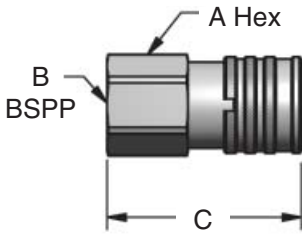

**Female Quick Disconnect**

Part No.	FK.10.G08.ZZZ	FK.10.G12.ZZZ
<b>A</b>	36 1.42	41 1.61
<b>B</b>	G 1/2	G 3/4
<b>C</b>	76.8 3.02	84 3.31

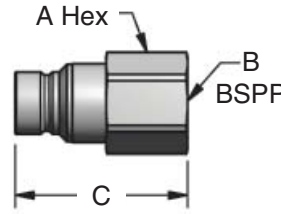

**Male Quick Disconnect**

Part No.	FL.10.G08.ZZZ	FL.10.G12.ZZZ
<b>A</b>	36 1.42	36 1.42
<b>B</b>	G 1/2	G 3/4
<b>C</b>	68 2.68	73 2.87

**Connected**

Part No.	FK.10.G08.ZZZ	FK.10.G12.ZZZ
	FL.10.G08.ZZZ	FL.10.G12.ZZZ
<b>A</b>	127.6 5.02	139.5 5.49

**Hose Protectors**

**Shield  
90.550.080**

Protective shields are used to extend the life of the 90.800 or 90.1200 hose by preventing wear. Each shield is 203 mm (8 inches) long and includes tie wraps for attaching to the hose at any position.



**Guard  
90.551.800.\_\_\_\_\_ (for use with 90.800 hose)  
90.551.1200.\_\_\_\_\_ (for use with 90.1200 hose)  
L (mm)**

Protective guard is used to extend the life of the hose by preventing wear. The polyethylene guard wraps around the hose for installation and removal at any time and is cut to a specified length.



**Coil  
90.552.800.\_\_\_\_\_ (for use with 90.800 hose)  
90.552.1200.\_\_\_\_\_ (for use with 90.1200 hose)  
L (mm)**

Protective coil is used to extend the life of the hose by preventing wear. This rugged steel coil is plated to resist rust and must be installed on the hose prior to attaching the hose ends and is cut to a specified length.



**Hose Strap  
90.504.800 (for use with 90.800 hose)  
90.504.1200 (for use with 90.1200 hose)**

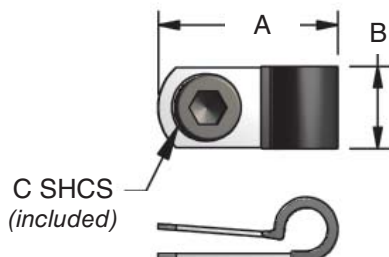

Part No.	90.504.800	90.504.1200
<b>A</b>	52 2.05	67.5 2.66
<b>B</b>	20 .79	26.5 1.04
<b>C</b>	M10	M12

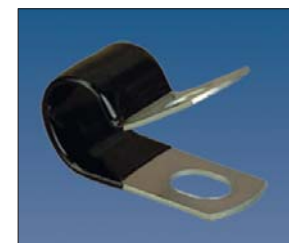

# Hydraulic Accessories

DADCO provides a variety of accessories for the **Power Cam™** and **Power Pump™** System. The figure below shows the proper use of the Bleed Port Reducer, Bleed Fitting and Bleed Block; used to bleed the air out of the **Power Cam™** prior to operation when the cam lacks accessibility.

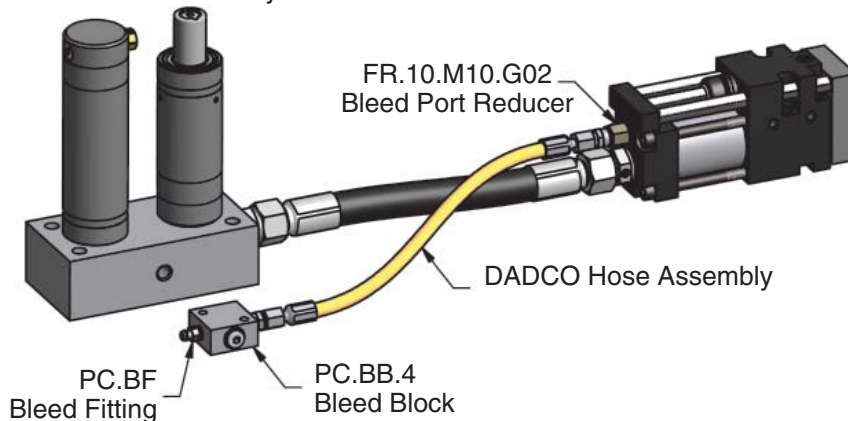

### Bleed Port Reducer FR.10.M10.G02

Use the Bleed Port Reducer to connect the **Power Cam™** to the Bleed Block.

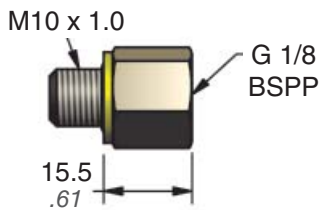

### Bleed Fitting PC.BF

Use the Bleed Fitting to evacuate air from the system.

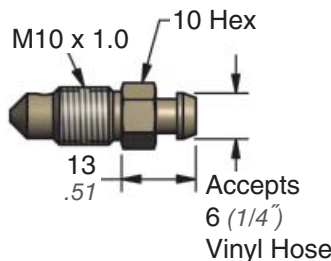

### Bleed Block PC.BB.4

Use the Bleed Block to remotely bleed the air out of the system.

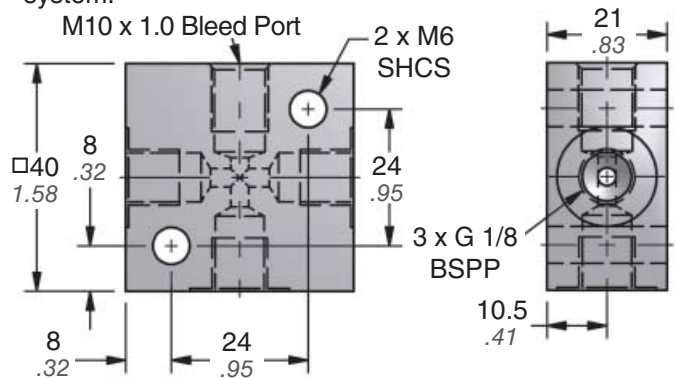

### Spanner Wrench

**SW-3** (for use with PP.B.015)

**SW-55** (for use with PP.B.040)

Use the Spanner Wrench in conjunction with a 5 mm hex key to remove the oil fill port plug from the hydraulic cylinder.



### Power Pump™ Filler

**PPF-6**

Use the PPF-6 with the DRS.FPA6 Oil Pump to fill and bleed the hydraulic oil from the System. Includes 10 ft. of low pressure vinyl hose.

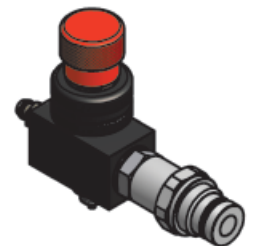

### Oil Pump DRS.FPA6

Air powered oil pump with 7.5 L (2 gallon) plastic container used for filling and replacing system oil. The assembly comes with hose and coupling and a high pressure filter on the outlet line.



Air Supply: 3-8 bar (40-150 psi)  
Reservoir: 7.5 L (2 gallon)  
Flow: 1.2 L/min (75 in<sup>3</sup>/min) at 7 bar (100 psi) inlet pressure

### Thrust Key

**PCK-15** (for use with PC.C.015)

**PCK-40** (for use with PC.C.040)



Part No.	PCK-15	PCK-40
A	12 +.00, -.05 .472 +.00, -.002	17 +.00, -.05 .669 +.00, -.002
B	12 +.00, -.05 .472 +.00, -.002	20 +.00, -.05 .787 +.00, -.002
C	45 1.77	95 3.74

### Operating Specifications

Medium:	Nitrogen Gas ISO VG 32 Hydraulic Oil	Maximum Velocity:	0.8 m/s (2.6 ft/s)
Operating Temperature:	10°C – 60°C (50°F – 140°F)	Max. Nitrogen Gas Pressure:	150 bar (2175 psi) See Bulletin #B11100 for system setup instructions.

### Power Pump™ Design Consideration

The Power Pump™ is connected to the Power Cam™ using a hydraulic hose assembly. Typically, hydraulic systems experience hose expansion during operation caused by an increase in hydraulic pressure. Hose expansion may be compensated in the Power Cam™ and Power Pump™ System by adjusting the travel of the Power Pump™. Use the equations below to calculate the additional travel required for the Power Pump™ to achieve the desired Power Cam™ travel.

Power Cam™ and Power Pump™ System – 15	Power Cam™ and Power Pump™ System – 40
$T = .00009 \times (F + 3.4) \times L$	$T = .000029 \times (F + 114) \times L$

- T** = Additional Power Pump™ Travel (mm)
- F** = Force to Perform Operation (kN)
- L** = Hose Length (mm)



#### Example:

The Power Cam™ (PC.C.015) must travel 35 mm to punch a hole that requires 12 kN of force and is connected to the Power Pump™ using a 1800 mm long hose. Using the equation given, the Power Pump™ (PP.B.015) will need to travel an additional 2.5 mm (37.5 mm total) to make certain that the Power Cam™ (PP.C.015) travels 35 mm.

$$T = .00009 \times (12 + 3.4) \times 1800$$

$$T = 2.5 \text{ mm}$$

Power Pump™ Travel = 35 mm + 2.5 mm  
Power Pump™ Travel = 37.5 mm

### Power Cam™ Design Considerations

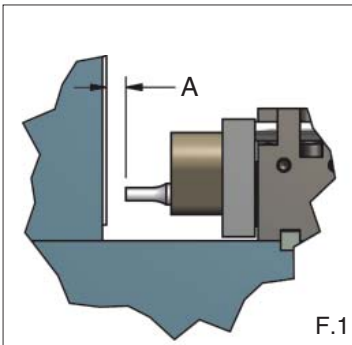

- Allow adequate clearance (A) for the tool prior to operation to achieve best results (F.1). DADCO recommends a clearance of 10% of the stroke length.
- Setting up the Power Cam™ without adequate clearance between the tool and the work piece may result in contact, causing damage (F.2) to the system.

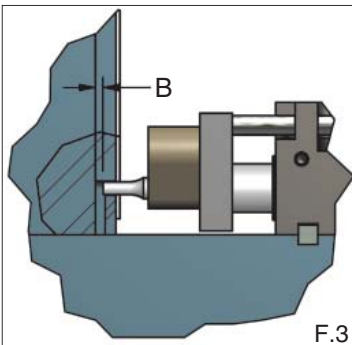
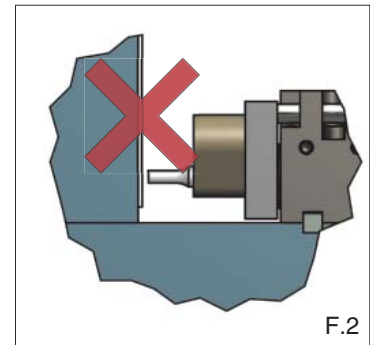

- Allow for clearance (B) at the end of the travel of the cam's tool to achieve optimal performance (F.3).
- Designs without adequate clearance for the travel of the tool, will result in overpressurization of the Power Cam™ and Power Pump™ System, which may lead to premature failure (F.4).

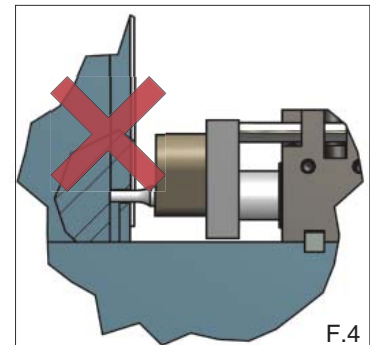

**Installation Recommendations**

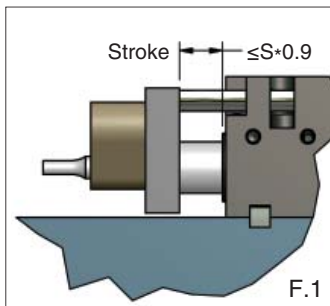

- DADCO's Power Cam™ and Power Pump™ System will permit travel of the full nominal stroke; however, a 10% stroke reserve is recommended to achieve optimal performance and safety (F.1, F.2).
- Verify that all air is bled out of the Power Cam™ and Power Pump™ System to ensure proper operation.
- Contact DADCO when linking multiple cams to one Power Pump™.
- Never compress the Accumulator in a vice or clamp outside of the die as damage can result.

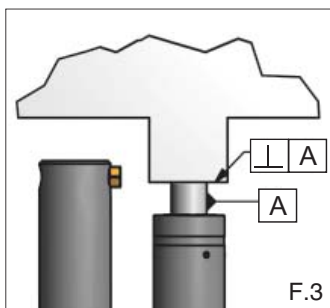
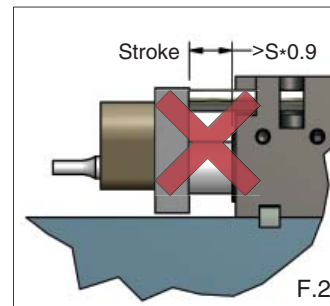

**Avoid Side Loading**

- Verify that there is adequate clearance in the die for the Accumulator. **DO NOT** impact the top of the Accumulator (F.3).
- Side loading resulting from press action or die construction causes increased wear on the bearing, seal and plunger of the Hydraulic Cylinder (F.4). Therefore, avoid side loading when possible (F.3).

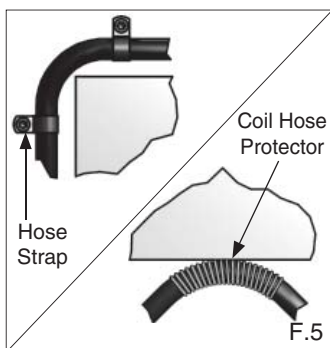
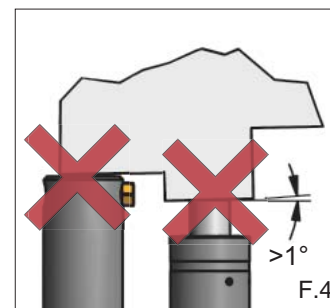

**Hose Installation**

- Use hose clamps to secure the hose in place and add hose protectors to the hose when necessary to protect against abrasion, thus extending hose life (F.5).
- Unprotected or improperly installed hydraulic hose may rub against rough surfaces causing wear and reducing hose life (F.6).

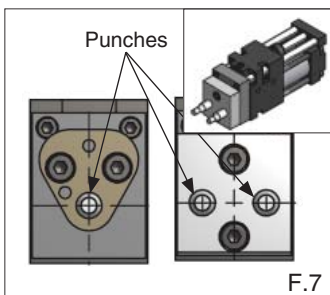
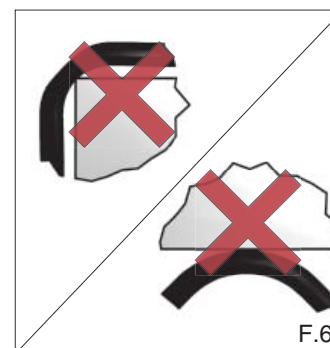

**Punch Installation**

- DADCO recommends locating a single punch on center of the drive rod on the tool plate for optimal performance (F.7).
- Punch(es) must be installed symmetrically, spaced through the centerline of the drive rod (F.7). Contact DADCO for more information.
- Punch(es) that are installed off-center or not placed symmetrically through the centerline of the drive rod will cause side load, increasing wear on the cam and reducing life (F.8).

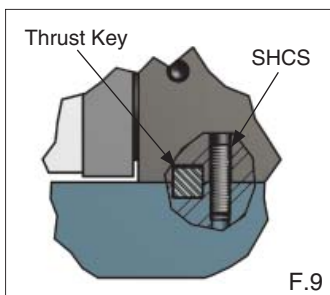
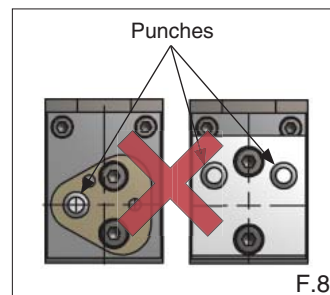

**Power Cam™ Mounting**

- Choose proper length screws to maximize thread engagement.
- A Thrust Key installed at the base of the cam must be used in addition to the two mounting screws to secure the cam to the die (F.9).
- Mounting screws are not capable of supporting the full load of the Power Cam™ (F.10).

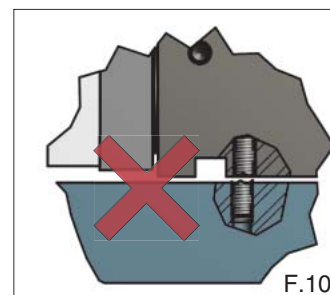

## Other DADCO Products



### SL2.090 and SL2.180 – Nitrogen Gas Spring Two Post Lifters

- 160 mm and 180 mm rail widths
- Powered by the **Micro 90™** and **Micro 180™**
- Stroke lengths available from 23 mm to 198 mm
- Two post for rail lift applications
- Compact Rail Plate available



### SLN.090 and SLN.180 – Micro Nitrogen Gas Lifter

- Compact design powered by the **Micro 90™** and **Micro 180™**
- Stroke lengths available from 25 mm to 125 mm
- Non-rotating design; provides lift and guidance
- Two guide rod options for single point, multipoint or rail lift applications



### Ultra Force® – U Series

- 19 mm to 195 mm in diameter
- Forces up to 199 kN
- Full range of standard stroke lengths up to 125 mm



### UH Series

- 32 mm to 120 mm in diameter
- Forces up to 66 kN
- Full range of standard stroke lengths up to 125 mm
- Common G1/8 port for linked operation



### ISO / 90.10 Series

- From 32 mm to 195 mm in diameter
- Forces up to 100 kN
- Full range of standard stroke lengths up to 300 mm
- Bolt-on or welded mounts available
- ISO Standards



### Linked System Components

- Monitor, control and adjust pressure from outside the die
- Variety of hose and fittings based on port style and application
- Control panels, distribution blocks, surge tanks and tools

# DADCO®

43850 Plymouth Oaks Blvd. • Plymouth, Michigan • 48170 • USA  
734.207.1100 • 800.DADCO.USA • fax 734.207.2222 • www.dadco.net

**The global leader in nitrogen gas spring technology**